

MAYTAG

TECHNICAL SPECIFICATIONS

Model PPG2GD Series

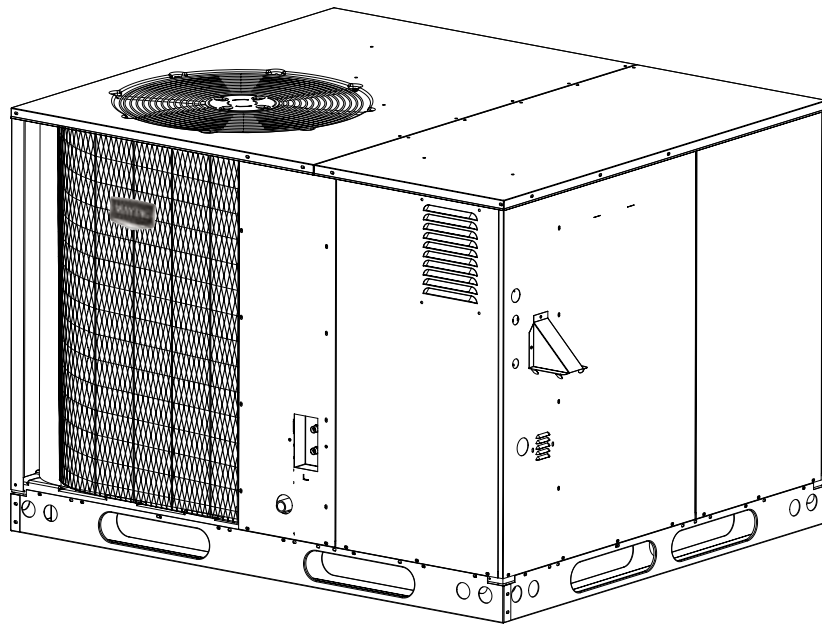

M1200 Product Line

**Single Packaged Gas/Electric Units
13 SEER, R-410A — 2 - 5 Ton Units**

- **M1200 - 12 YEAR ALL PARTS LIMITED WARRANTY**
- **M1200 WITH UPGRADED WARRANTY PACKAGE - 12 YEAR ALL PARTS & LABOR LIMITED WARRANTY**
- **Both the standard and upgraded limited warranty packages offer a 12 Year Dependability Promise to replace the entire unit, if the unit's major component (heat exchanger or compressor) fails within the first 12 years of operation, to the original owner.**
- **Product registration (by consumer or dealer) required for 12-year Warranty and Dependability Promise within a limited period of time after the installation. See current warranty document for details. This can be viewed at www.maytaghvac.com or ask your sales representative.**
- **Dealer is responsible for registration of labor portion of warranty.**
- **Also when registered, this product is upgraded to a limited lifetime heat exchanger warranty.**



The PPG2GD Series single packaged gas/electrics are high efficiency self contained cooling units that can be installed on the roof or on a slab. The convertible unit design makes installations simple in all applications. Units are ETL and ETLc listed. The unit is truly designed with the contractor and the consumer in mind.

Features and Benefits

- **R-410A Refrigerant**
Environmentally Friendly.
- **Compact Footprint/Low Profile**
Easy to handle and transport.
- **Heavy-Gauge, Full Perimeter Base Rails**
Facilitates forklift handling and curb mounting.
- **Convertible Air Delivery**
Horizontal or downflow to accommodate rooftop or horizontal application.
- **Galvanized Steel Cabinet**
Unit is trimmed in a silicone-protected polyester finish with a 950 hour salt spray finish that resists corrosion 50% better than comparable units.
- **Plastic Coated Coil Guard and Mesh Hail Guard**
Will never rust and protects the coil from being damaged by balls, lawnmowers, hail etc.
- **Externally Accessible Service Ports**
Quick access to refrigerant system without disrupting operation.
- **Access to Controls and Major Components**
Easy in and out service.
- **Corrosion-Resistant Drain Pan**
Quickly drains away evaporator condensate.
- **Smaller Panels, Great Fit and Finish, Total Seal** — Well-designed, quality construction. Drip edge on top panels whisks away rainwater. Embossed bottom pan keeps blower component compartment dry.
- **Proven, Industry Standard Components**
Easier service and availability.
- **Quiet Operation and Low Vibration**
20" fan blade combined with custom venturi condenser fan. Compressor sound blanket is standard.
- **Accessories**
Roof curbs, economizers, fresh air dampers and more.
- **SmartStart® Control Board** — Provides extended life to ignitors using hot surface ignition technology. Programmed to learn the heat-up characteristics of the ignitor, then adapt the ignition time to the characteristics of the furnace so the ignitor is energized appropriately.
- **Quiet Plus™ Compressor Sound Blanket** — Engineered to significantly reduce unwanted noise.
- **High/Low Pressure Switch**
Added compressor protection.